

GIKEN

SILENT PILER **F201**

for U Sheet Piles
400-600mm wide



Modular model applicable to U Sheet Piles (400-600mm wide)

SILENT PILER F201

Silent Piler F201

Flexible and Functional Formula

The F201 features a new modular design developed by optimising all the parts and drastically modifying the structure, shape, and material. Not only are the main component parts more versatile, it is also equipped with a cutting-edge control system, and realising high functionality and longer operation life.

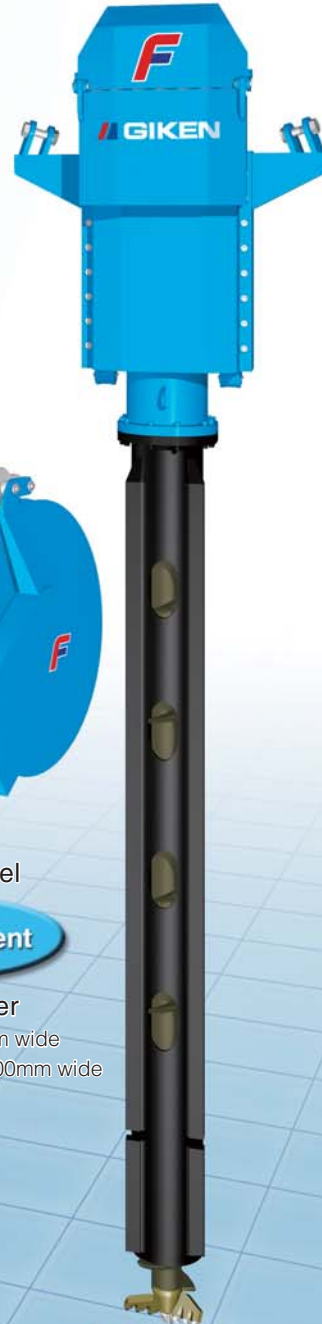

Modular Base Components

- Leader Mast
- Slide Frame
- Saddle
- Clamps



Attachment

Piler Jet Reel



Hose Reel

Attachment

- Pile Auger
 - for 400mm wide
 - for 500-600mm wide

Compatible with Various Types of Chuck



400mm wide Standard Mode Chuck



400mm wide Super Crush Mode Chuck



500,600mm wide Standard Mode Chuck



500,600mm wide Super Crush Mode Chuck

1 Applicable to 400-600mm wide U Sheet Pile and soft to hard ground conditions

F201 has wider adoptability and is applicable to Standard Mode, Water Jetting Mode, and Super Crush Mode and 400mm, 500mm and 600mm wide U sheet pile by changing the chuck and chuck frame, and equipping suitable attachments.

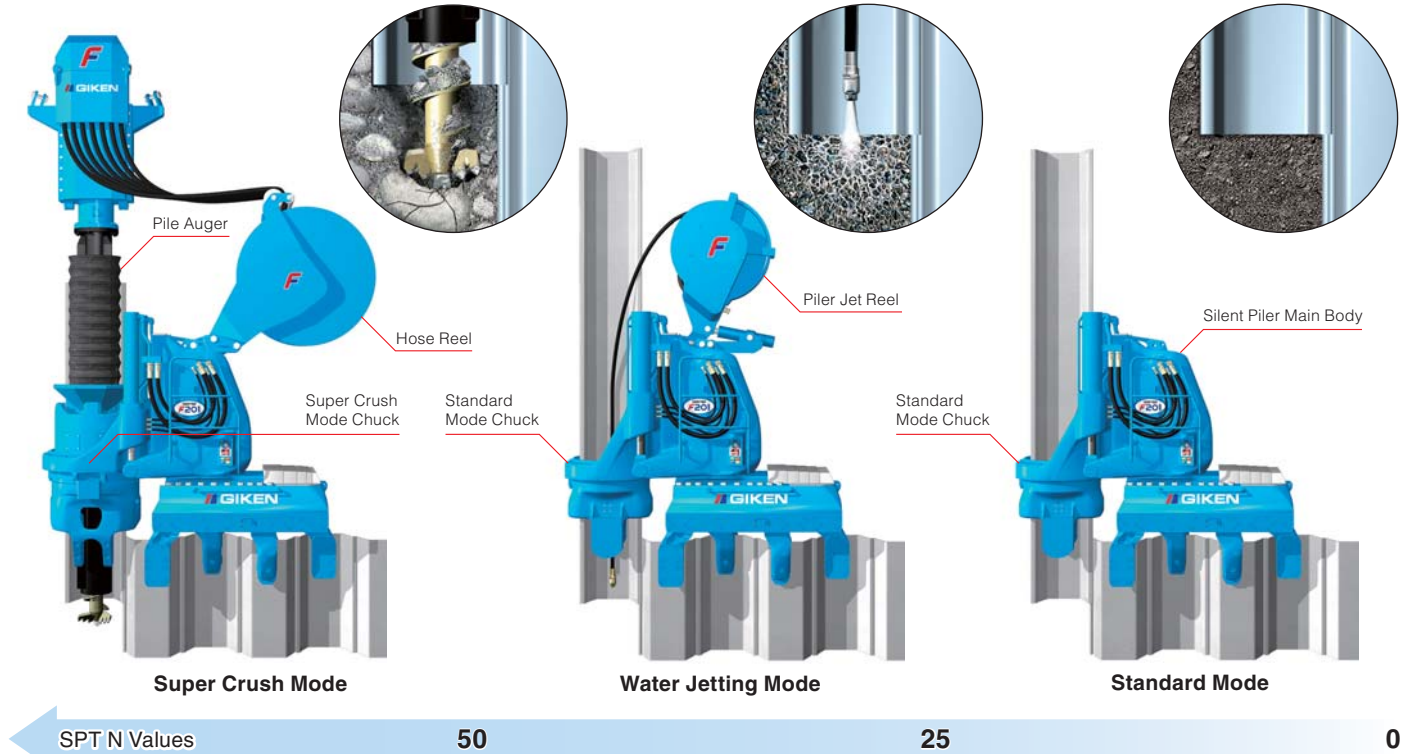

2 Longer Operational Life and Higher Functionality by New Control System

The new control system manages the position of the press-in machine and controls load generation from press-in work during operation, maximising the durability of each part. Also, control of the machine is remarkably improved by the Press-in Force Control System and the Phaseless Linear Auger Torque Control System.



Pile width corresponding to the Chuck is automatically detected.

Position of the Press-in Machine is automatically detected

Up/Down Stroke Force is optimised.

Maximum Up/Down Stroke Force is regulated.

Load applied to Silent Piler can be reduced.

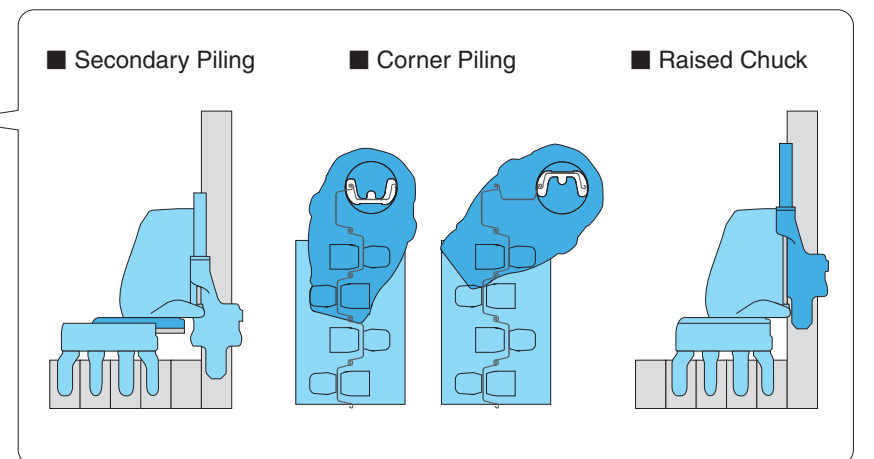

3 Pile Installation into Hard Ground

The "Directional Coring Theory", GIKEN's original theory, makes the Hard Ground Press-in Method able to install sheet piles into difficult ground conditions such as gravelly soil and cobble or boulder mixed soil without losing the advantages of the Press-in Method. The augering area can be reduced to assist pile installation, minimising volume of spoil and disturbance to the soil strata. Hence, high bearing capacity is available from sheet piles which are installed by the Hard Ground Press-in Method.

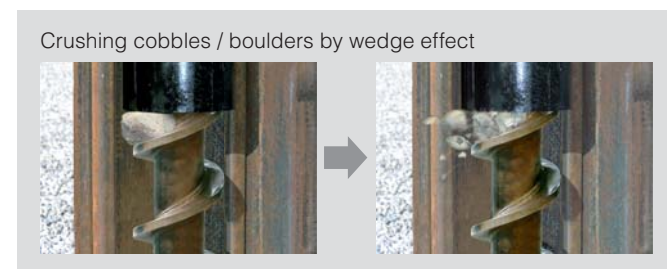
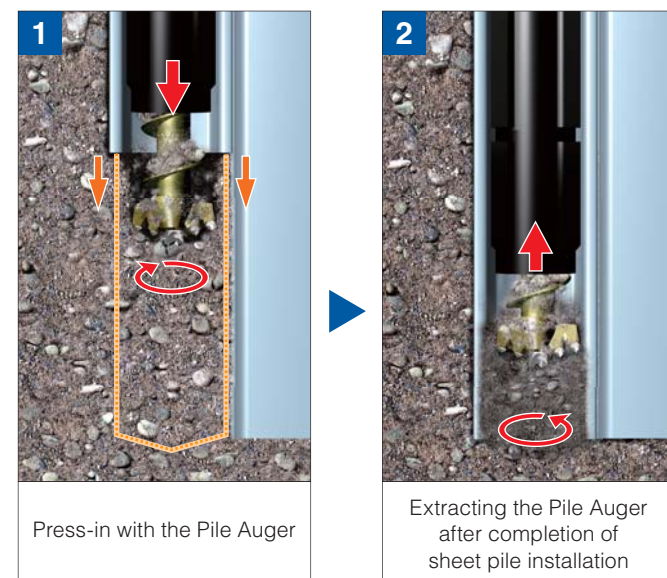

Locking Function

Lock functions in the leader mast, chuck and clamps secure Silent Piler against drilling torque and increase drilling efficiency and accuracy of pile installation.

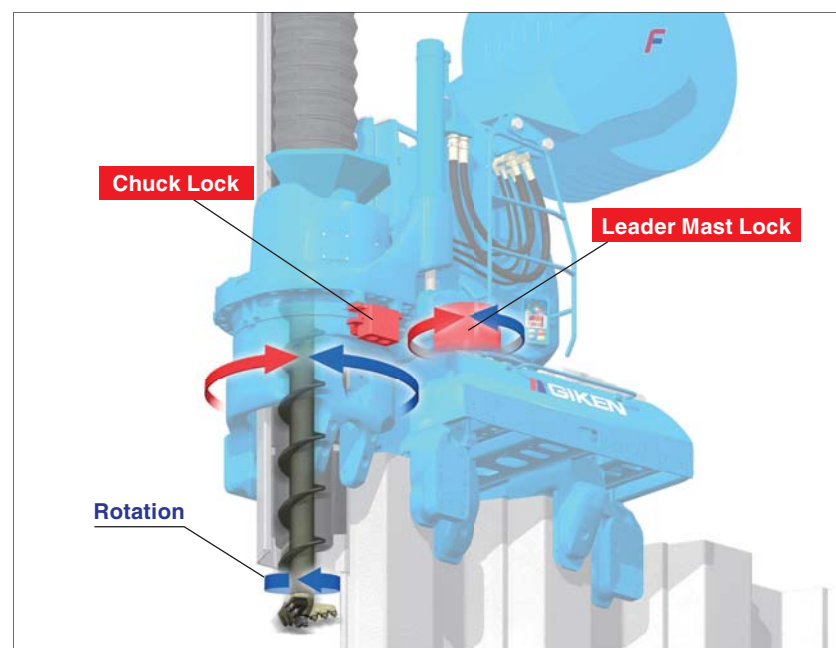

4 Outstanding Environmentally-Friendly Design

Low Emission Engine

The Power Unit of the F201 is a new generation model and has environmentally-friendly specifications. It is designed with strict concepts for clean emissions with high combustion efficiency and GIKEN's original hydraulic control technologies.



Ultra Low Noise Level

It clears allowable construction noise levels in many industrialised countries.

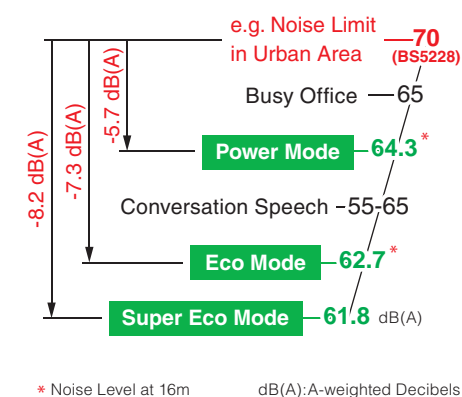

Standard Application of Biodegradable Oil

The F201 uses bio-degradable Piler Eco Oil and Piler Eco Grease. Hence, if hydraulic oil or grease is spilled into soil or water, there will be no environmental damage to the surrounding ecosystem. In addition, the machines are painted with TX-Free non-lead paint*.

* Environmentally-friendly paint which does not contain toluene, xylene and lead based pigment.



5 Scientific Execution of Press-in Work & Advanced IT Functions

GIKEN IT System

GIKEN's engineers can monitor individual Silent Pilers, such as operating condition, maintenance records and location. Quick advice for any technical troubles is available promptly and appropriate information can also be provided to prevent troubles.

* The system is not available in the countries where authorisation for usage cannot be acquired.

Press-in Monitoring and Data Logging System

Press-in monitoring data can be used for quality control and information modelling of the foundation. Operators are able to keep working while checking data such as press-in force, auger torque, and working hours of press-in work, on a tablet or PC (both optional extras).

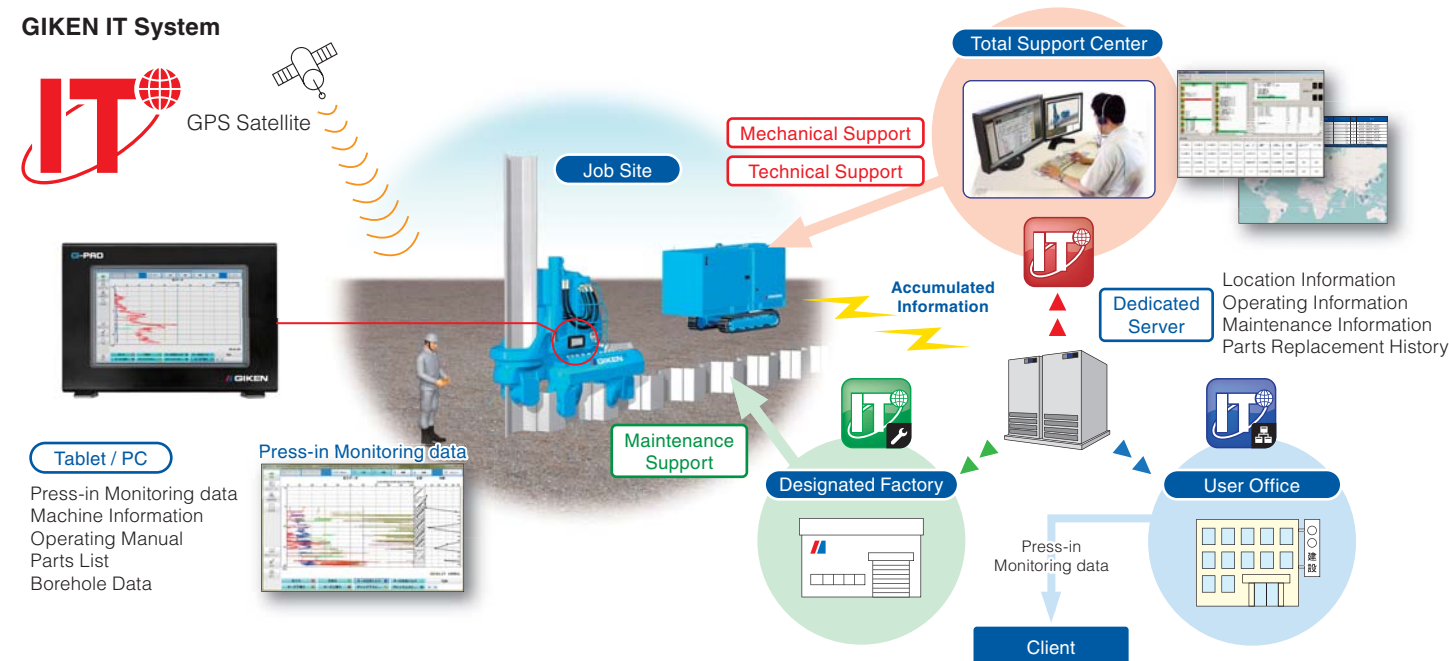

Dimensions & Specifications

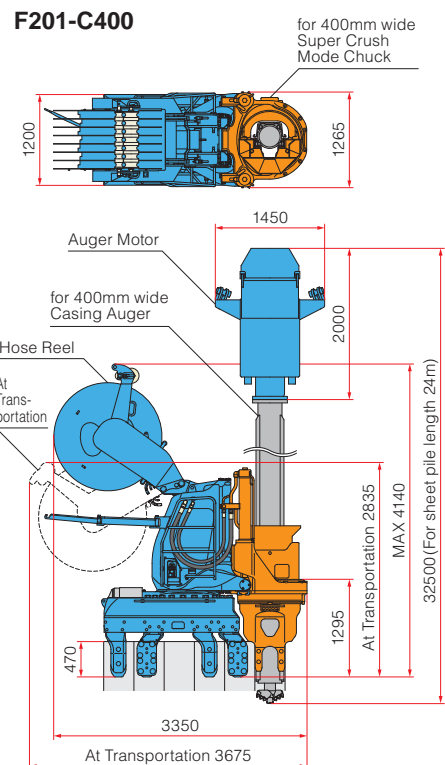
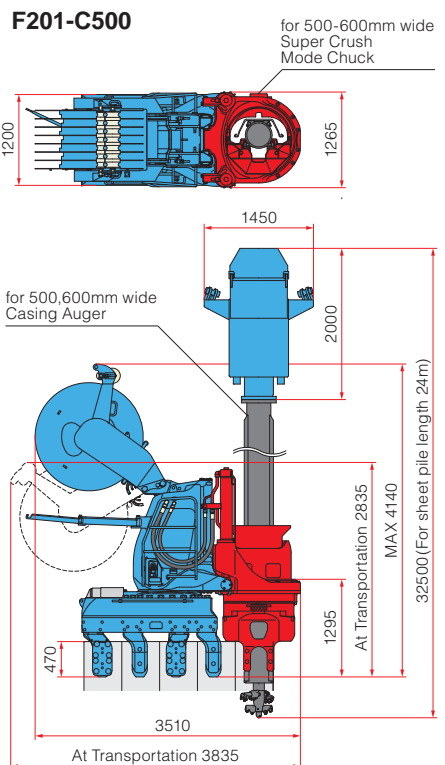
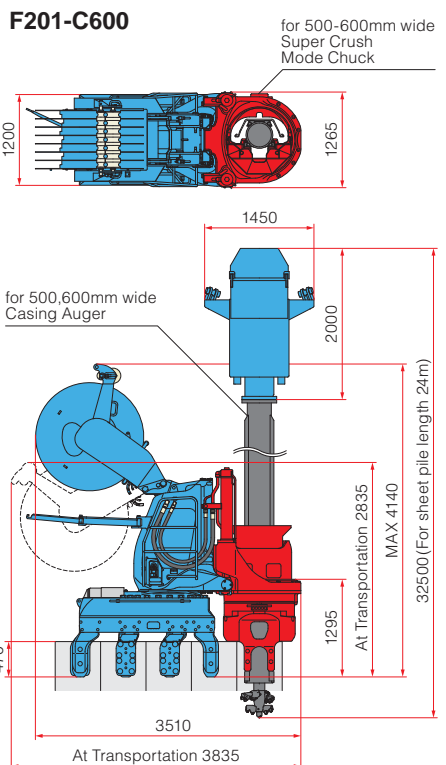
	400mm wide	500mm wide	600mm wide
Super Crush Mode	F201-C400  <p>for 400mm wide Super Crush Mode Chuck</p> <p>1200</p> <p>1265</p> <p>1450</p> <p>Auger Motor</p> <p>for 400mm wide Casing Auger</p> <p>Hose Reel</p> <p>At Transportation</p> <p>MAX 4140</p> <p>32500 (For sheet pile length 24m)</p> <p>1295</p> <p>3350</p> <p>At Transportation 3675</p>	F201-C500  <p>for 500-600mm wide Super Crush Mode Chuck</p> <p>1200</p> <p>1265</p> <p>1450</p> <p>Auger Motor</p> <p>for 500,600mm wide Casing Auger</p> <p>Hose Reel</p> <p>At Transportation</p> <p>MAX 4140</p> <p>32500 (For sheet pile length 24m)</p> <p>1295</p> <p>3510</p> <p>At Transportation 3835</p>	F201-C600  <p>for 500-600mm wide Super Crush Mode Chuck</p> <p>1200</p> <p>1265</p> <p>1450</p> <p>Auger Motor</p> <p>for 500,600mm wide Casing Auger</p> <p>Hose Reel</p> <p>At Transportation</p> <p>MAX 4140</p> <p>32500 (For sheet pile length 24m)</p> <p>1295</p> <p>3510</p> <p>At Transportation 3835</p>

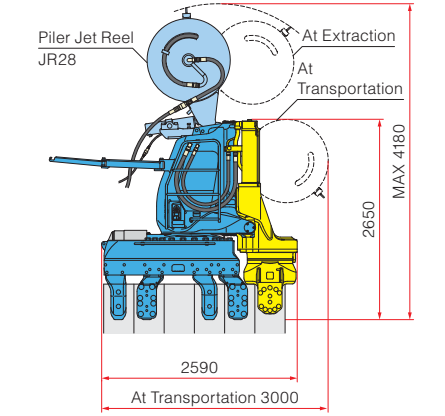
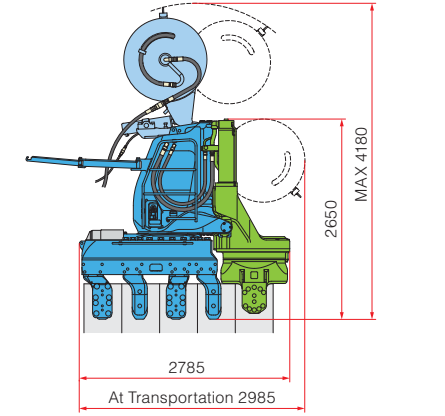
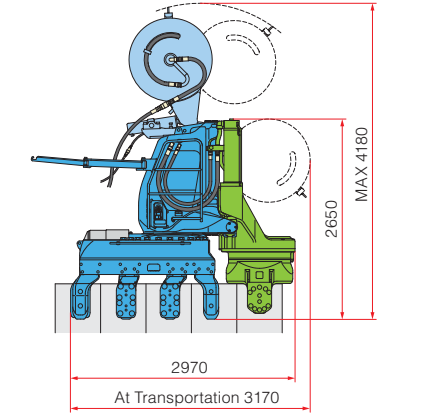
	400mm wide	500mm wide	600mm wide
Water Jetting Mode	F201-400  <p>Piler Jet Reel JR28</p> <p>At Extraction</p> <p>At Transportation</p> <p>MAX 4180</p> <p>2650</p> <p>2590</p> <p>At Transportation 3000</p>	F201-500  <p>MAX 4180</p> <p>2650</p> <p>2785</p> <p>At Transportation 2985</p>	F201-600  <p>MAX 4180</p> <p>2650</p> <p>2970</p> <p>At Transportation 3170</p>

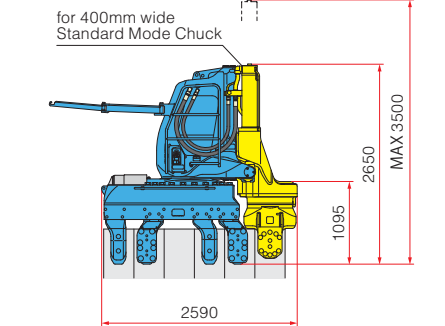
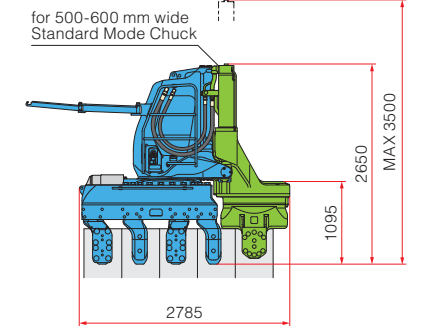
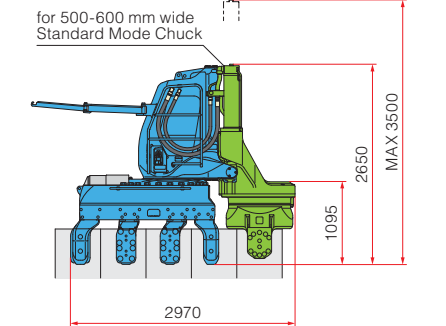
	400mm wide	500mm wide	600mm wide
Standard Mode	F201-400  <p>for 400mm wide Standard Mode Chuck</p> <p>MAX 3500</p> <p>2650</p> <p>1095</p> <p>2590</p>	F201-500  <p>for 500-600 mm wide Standard Mode Chuck</p> <p>MAX 3500</p> <p>2650</p> <p>1095</p> <p>2785</p>	F201-600  <p>for 500-600 mm wide Standard Mode Chuck</p> <p>MAX 3500</p> <p>2650</p> <p>1095</p> <p>2970</p>

F201 Specifications

- Super Crush Mode**

Max. Press-in Force	800 kN
Max. Extraction Force	900 kN
Stroke	850 mm
Press-in Speed	0.5 ~ 4.5 m/min
Extraction Speed	1.1 ~ 9.4 m/min
Control System	Radio Control
Mass (Main Body & Hose Reel)	for 400mm wide sheet pile 13110 kg for 500, 600mm wide sheet pile 13610 kg

Hose Reel HR17C

Mass(Standard) 2760 kg (including Hose Reel Bracket)

Pile Auger PA22

Applicable pile length (Standard)	Max 24 m*
Auger Motor	1850 kg
Mass Casing Auger	for 400mm wide sheet pile 9050 kg for 500, 600mm wide sheet pile 10050 kg
Total Mass	for 400mm wide sheet pile 10900 kg for 500, 600mm wide sheet pile 11900 kg

*Max 30m in special mode

- Water Jetting Mode**

Max. Press-in Force	1500 kN
Max. Extraction Force	1600 kN
Stroke	850 mm
Press-in Speed	1.4 ~ 30.0 m/min
Extraction Speed	1.1 ~ 23.2 m/min
Control System	Radio Control
Mass (Main Body & Piler Jet Reel)	for 400mm wide sheet pile 10820 kg for 500, 600mm wide sheet pile 11120 kg

Piler Jet Reel JR28

Applicable pile length	Standard 17.0 m (Max. 27.0 m)
Mass	820 kg

Piler Jet Reel is an optional item

- Standard Mode**

Max. Press-in Force	1500 kN
Max. Extraction Force	1600 kN
Stroke	850 mm
Press-in Speed	1.4 ~ 30.0 m/min
Extraction Speed	1.1 ~ 23.2 m/min
Control System	Radio Control
Mass (Main Body)	for 400mm wide sheet pile 10000 kg for 500, 600mm wide sheet pile 10300 kg

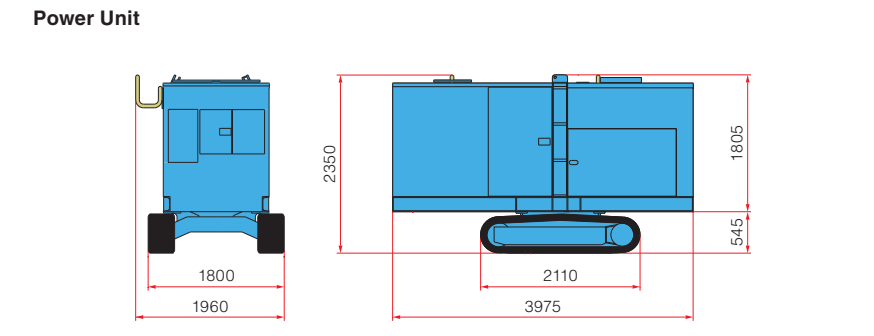

Power Unit		EU30013
Power Source	Diesel Engine	
Power Mode	230 kW(313 ps)/1800 min ⁻¹	
Rated Output	Eco Mode	204 kW(278 ps)/1600 min ⁻¹
	Super Eco Mode	179 kW(243 ps)/1400 min ⁻¹
Fuel Tank Capacity	500 L	
Hydraulic Reservoir	Piler ECO Oil 490 L	
Moving Speed	1.4 km/h	
Mass	6400 kg (with 20m Hose)	

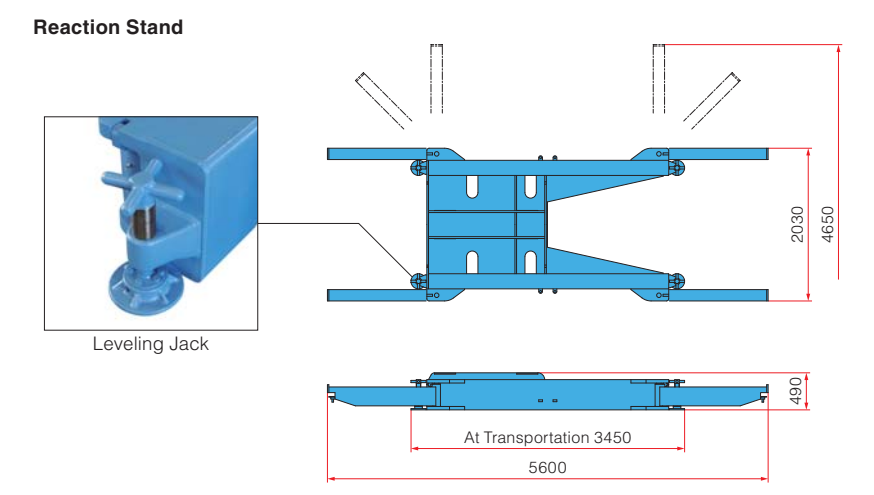

Reaction Stand (with Leveling Jack)	
Mass	1900 kg

Chuck Mass

Sheet Pile Width	Standard Mode Chuck	Super Crush Mode Chuck
500, 600 mm	2850 kg	3400 kg
400 mm	2550 kg	2900 kg

The above specifications are subject to alteration without prior notice

Accessories

Standard Accessories

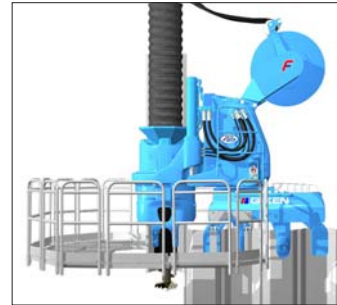

Piler Stage



Chuck Stage *

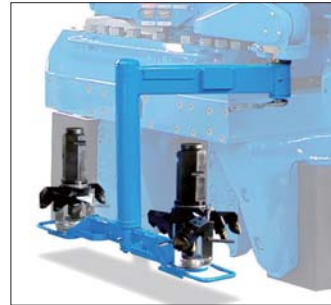

Auger Head Replacement Attachment *

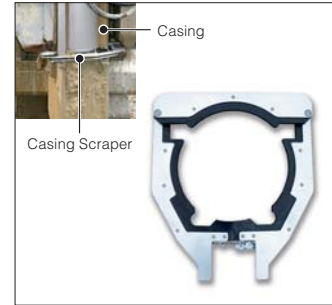

Casing Scraper *

* Available for Super Crush Mode only.

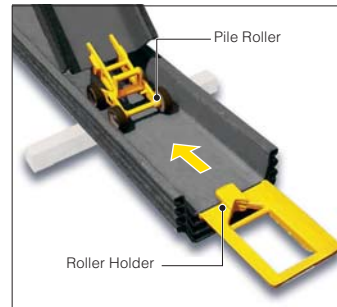

Pile Roller

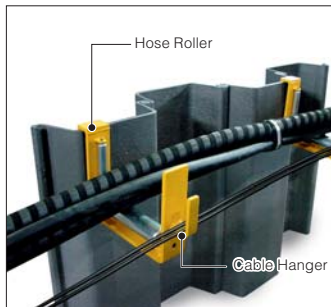

Hose Roller



Pile Laser



Module Box

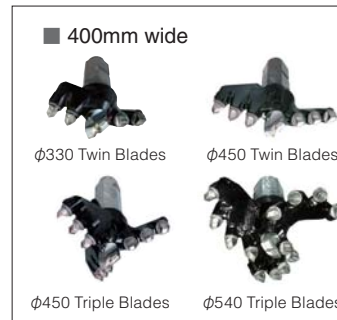

■ 400mm wide

φ330 Twin Blades φ450 Twin Blades
φ450 Triple Blades φ540 Triple Blades



■ 500-600mm wide

φ400 Twin Blades φ540 Twin Blades φ540 Triple Blades
φ580 Twin Blades (Retractable)* φ685 Triple Blades

Auger Head *

* for 600mm wide only

Optional Accessories



Piler Jet Reel (JR28)

F201 Project Data Sheet

F201 Demonstration Test



Project : Cofferdam Test Piling
 Location : Dong Gang Business District, Dalian China
 Period : November 2013 ~ December 2013
 Silent Piler : F201
 Type of Sheet Pile : U Sheet Pile SP IV
 Pile Length : 12m (Standard Mode)
 12m, 24m (Super Crush Mode)



▼ Borehole Log

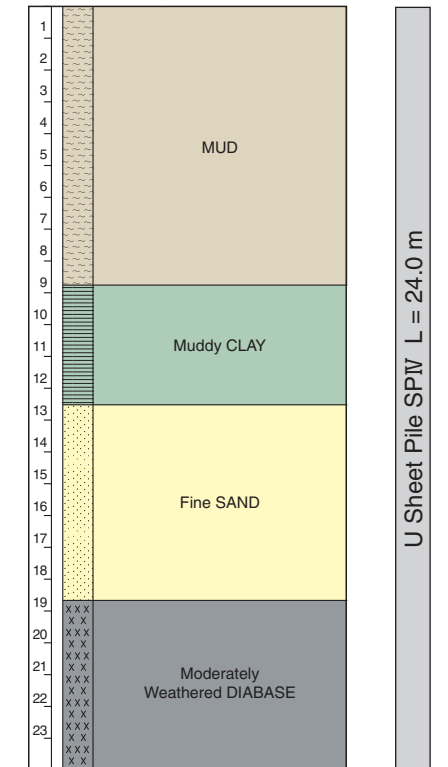

Emergency Land Slide Remedial Works



Project : Emergency Channel Construction Works
 Location : Oshima Town, Tokyo
 Period : March 2014 ~ May 2014
 Silent Piler : F201
 Type of Sheet Pile : U Sheet Pile SP III
 Pile Length : 7.0 m



▼ Borehole Log

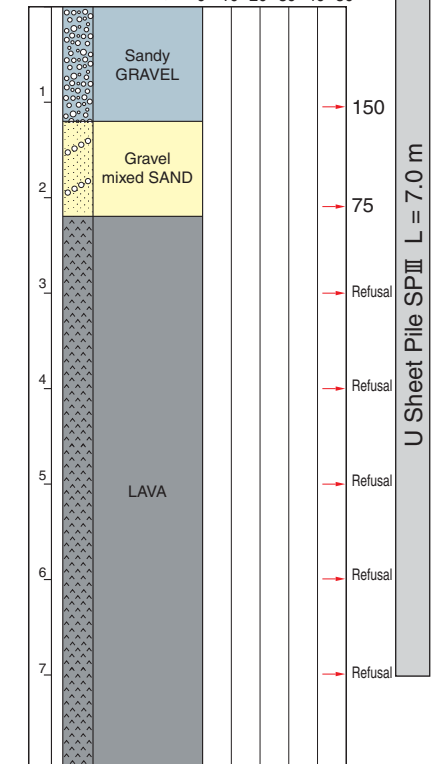

*Extrapolated SPT-N Value when over 50.

Drainage Restoration Works in Dense Residential Area



Project : Machida City Public Sewer System, Storm-Water Sewer Construction Works
 Location : Machida City, Tokyo
 Period : May 2013
 Silent Piler : F201
 Type of Sheet Pile : U Sheet Pile SP VL
 Pile Length : 8.5 m

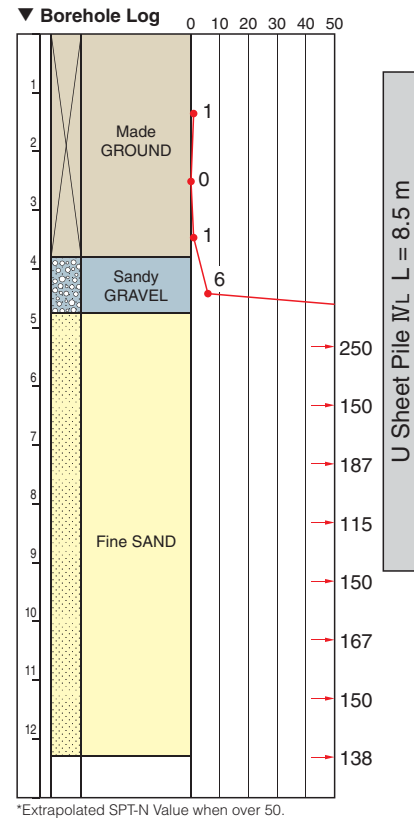

Installation of Sheet Pile Cut-off Wall into Hard Ground



Project : Demolition of Miyagi Prefectural Public Health and Environment Bldg.- Second Phase
 Location : Sendai City, Miyagi
 Period : October 2013 ~ November 2013
 Silent Piler : F201
 Type of Sheet Pile : J Pocket Pile JFESP-4WS, U Sheet Pile SP IIw
 Pile Length : 4.0 ~ 7.5 m

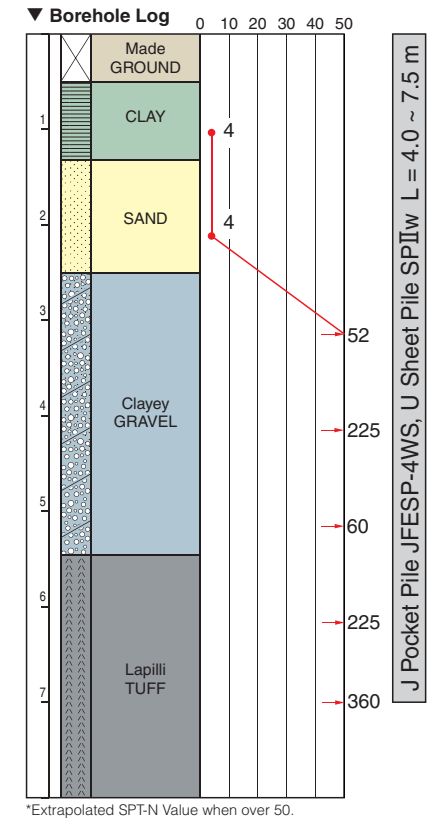

River Dike Disaster Remedial Works



Project : Embankment Restoration Work Section 4, Natori River
 Location : Natori City, Miyagi
 Period : September 2013 ~ October 2013
 Silent Piler : F201
 Type of Sheet Pile : U Sheet Pile SP IIIw and SP IVw
 Pile Length : 7.5 ~ 16.5 m

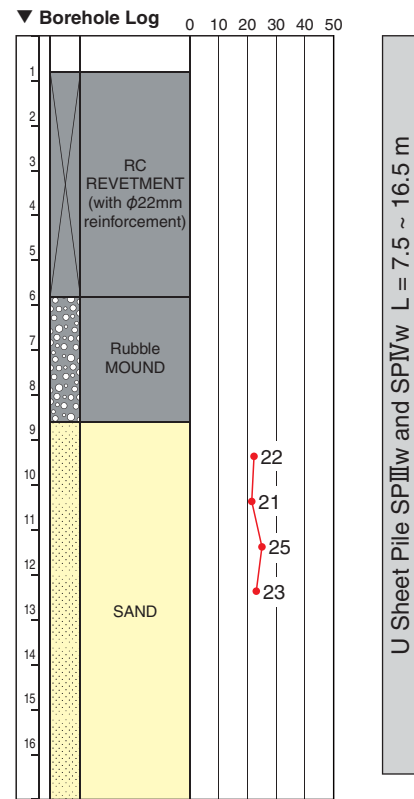

Visit the following URL for more details.

GIKEN Project Leaflet Database
<http://www.gtoss.net/en/pressin-archive>



Data sheets can be searched and downloaded by category.

